

1935-40 FORD 2 POSITION ADJUSTABLE WELD ON REAR KIT

**POSIES
SUPER SLIDE SPRINGS
AND
HOT ROD PARTS**

219 N. Duke Street Hummelstown, PA 17036

Phone 717.566.3340 Fax 717.566.5440

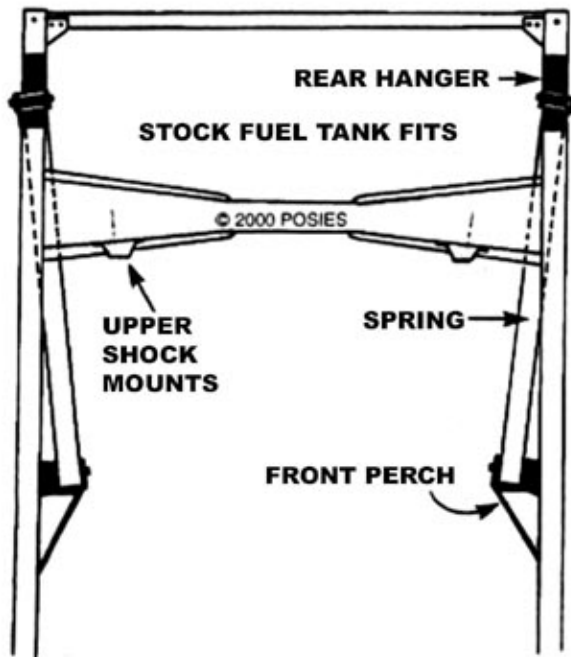

TOP VIEW OF FRAME LOOKING TOWARDS REAR

TIP: TO DETERMINE ANGLE OF REAR HANGER, INSTALL FRONT PERCH AND TEMPORARILY BOLT SPRING AND SHACKLE IN PLACE

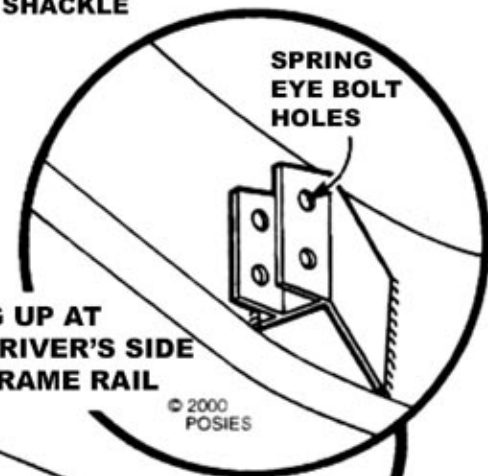

LOOKING UP AT INSIDE DRIVER'S SIDE BOXED FRAME RAIL

CUT 1 1/8" HOLE ON SIDE OF FRAME RAIL FOR REAR HANGER 15/16" ON CENTER FROM BOTTOM OF FRAME.

C-NOTCHING THE FRAME IS NECESSARY

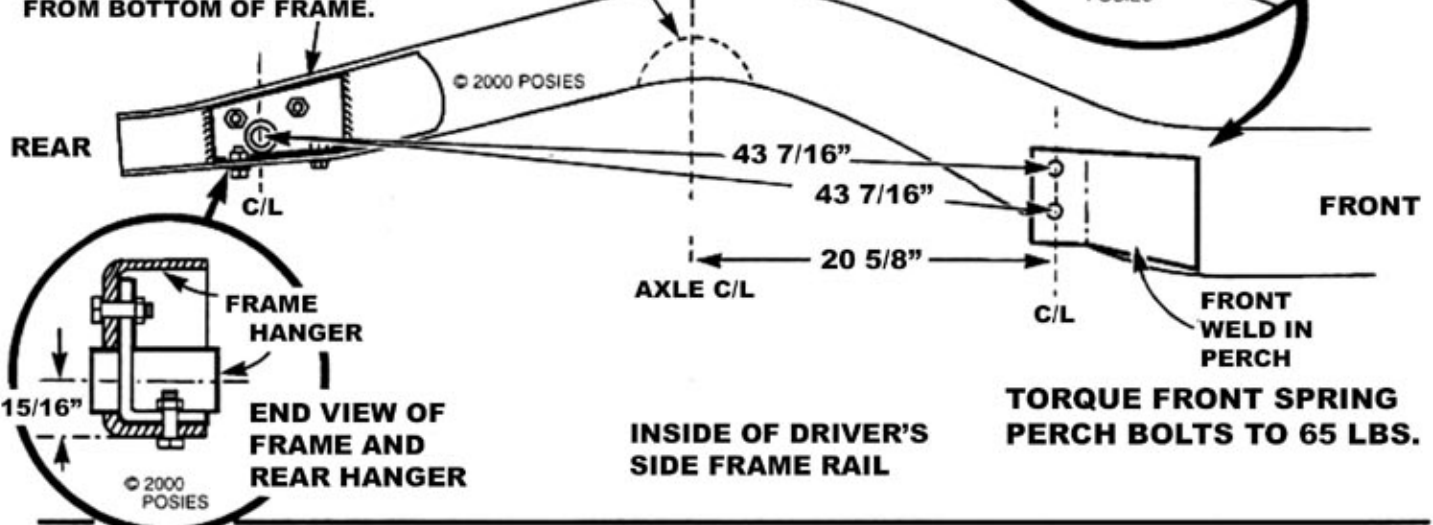

TORQUE FRONT SPRING PERCH BOLTS TO 65 LBS.

INSIDE OF DRIVER'S SIDE FRAME RAIL

NOTE:

- MAKE SURE THAT THE FRAME IS LEVEL AND SQUARE
- THE MOUNTING BRACKETS MUST BE FULLY WELDED BEFORE FINAL INSTALLATION

KIT INCLUDES:

- | | |
|--------------------------------------|-------------------------------------|
| (2) FRONT WELD-ON SPRING PERCHES | (2) REAR HANGER SLEEVE AND BRACKETS |
| (2) FRONT SPRING EYE BOLTS & NYLOCKS | (2) SHACKLES |
| (2) AXLE SADDLES | (2) LOWER SHOCK MOUNTS |
| (4) U-BOLT | (2) SUPERSLIDE SPRINGS |
| (2) U-BOLT PLATES | |

IMPORTANT:
MAKE SURE THAT YOU TIGHTEN THE SHACKLE NUTS SO THAT THE LAST THREAD IS PAST THE NUT. YOUR SHACKLE BUSHINGS WILL THEN LAST MANY MILES AND WORK CORRECTLY.

